

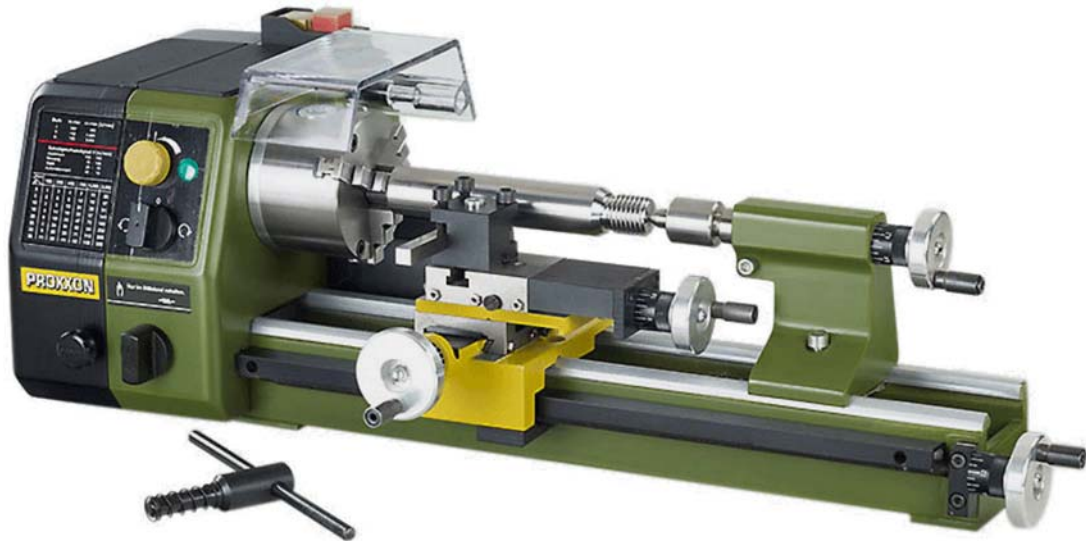

**The new generation with system accessories.
Made in Germany!**



Precision lathe PD 250/E

**For face, longitudinal and taper turning, thread-cutting.
For machining steel, brass, aluminium and plastic.
Mounting flange for fastening the mill/drill head PF 230.**

Centre distance 250mm. Swing 70mm. Height over cross slide 43mm.

Machine bed: Of cast iron, wide-legged prismatic guide. For vibration-free work even at high loads. Rear flange for mounting the mill/drill head PF 230. Covered lead spindle.

Headstock: Of die-cast aluminium. Precision bearing mounted main spindle (run-out without chuck 1/100mm) with 10.5mm opening. Chuck side 70mm hollowed to 14mm. With MK 2 bore. Rotary switch for engaging the automatic feed via lead and feed spindle (optionally 0.05 or 0.1mm/rev.).

Tailstock: Of die-cast aluminium. Sleeve \varnothing 18mm, retractable up to 30mm. With millimetre scale, MK 1 bore and live centre.

Support: Bed carriage made of die-cast zinc. Cross slide and top slide of steel (adjustment 60 or 45mm). Turning tool post for cutting tools size 8 x 8mm.

Drive: Quiet DC special motor with 3-stage belt drive for 300 - 900 and 3,000rpm. With additional speed control (full-wave electronics) continuously adjustable to 100 - 300 or 1,000rpm, depending on belt ratio. Clockwise - anticlockwise rotation. Main switch with emergency stop function and restart protection.

Lathe chuck: High quality 3-jaw chuck as per DIN 8386 Class 1 (concentricity tolerance 0.04mm). Capacity through reversing jaws from 2 - 75mm. Including lathe chuck guard with safety shutdown.

Handwheels: Of aluminium, with adjustable scale ring (1 division = 0.05mm, 1 revolution = 1mm).

Thread cutting device: With change gears for left-hand and righthand threads of the most important metric pitches (0.5 - 0.625 - 0.7 - 0.75 - 0.8 - 1 - 1.25 - 1.5mm).

Other technical data: 230V. 50/60Hz. Size L 560, W 270, H 170mm. Weight approx. 12kg.

NO 24 002



See us on YouTube!

Accessories for the PD 250/E

Radius cutting attachment

Is mounted on the cross slide in place of the tool holder. For producing convex and concave shapes, for turning radii or 3/4 spheres with radii of 32mm max. Height adjustable tool holder (boring tool tip adjustable from 30 through 45mm above cross slide) for use with FD 150/E, PD 250/E, PD 400 and older PROXXON lathes. Dimensions: base plate 67 x 50mm, height 55mm. Including finishing cutter 8 x 8 x 80mm. In wooden box with sliding lid.

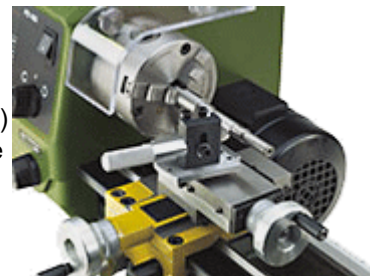

NO 24 062

1 Quick change tool post - easy to use!

For quick tool change and easy height adjustment. Includes 2 tool holder elements.

NO 24 026



2 Additional quick change tool holder (separately)

Can be used with the above above-mentioned quick change tool post.

NO 24 024

Chip collecting tray with splash guard

Made from 1.5mm thick sheet metal, powder coated. Bevelled edges at the front and back allow slight clean-ing. Mounting hole and raised base to secure lathe are pre-drilled. L 550 x W 240 x H 160mm. The depicted lathe is not included in the offer.

NO 24 008

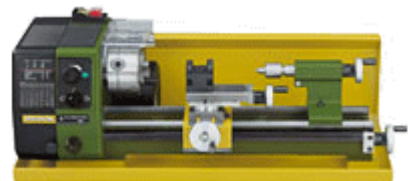

4-jaw chuck with independent jaws

For clamping angular and asymmetrically shaped work pieces. Capacity up to 80mm. Chuck Ø 75mm.

NO 24 036



Collet set with ER 20 collets:

For extreme true concentric accuracy. 2 - 10mm.

For high precision machining of round parts. The collet set is mounted instead of the lathe chuck. With 8 collets (2 - 2.5 - 3 - 4 - 5 - 6 - 8 and 10mm). Packed in a wooden box.

NO 24 038



Centre turning attachment.

For highest accuracy with high rotational precision.

This includes: 1 face plate, 2 fixed centres (MK 2 and MK 1/short) and 1 drive dog. Packed in a wooden box.

NO 24 014



Fixed steady for longer work pieces

Especially for boring. Also required if the tailstock cannot be used to "counter". Up to Ø 40mm.

NO 24 010



Professional gear chuck with MK 1

For the tailstock of the PD 250/E. Capacity up to 10mm.

NO 24 020



Self-centering 3-jaw chuck

Identical to chuck of lathe PD 250/E. High quality clamping fixture as per DIN 8386, Class 1 (concentricity accuracy 0.04mm). Capacity through reversing jaws from 2 - 75mm. Suitable for PD 250/E and the dividing attachment NO 24 044.

NO 24 034



14-piece parallel supports set

Ground in pairs. For adjusting work on drilling machines, lathes and milling machines. Made of high-alloy, hardened steel (58 - 62 HRC). Parallel accuracy 0.02mm. 2 each of 8 x 10, 15, 20, 25, 30, 35 and 40mm. Length 100mm. Packed in a wooden box.

NO 24 266



Cutting tools of high quality cobalt HSS steel, ground

Five piece set

One each roughing out, parting, finishing cut, left and right cutter. Comes in wooden box with sliding lid. 8 x 8 x 80mm.

NO 24 530

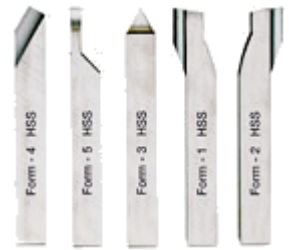

Three piece thread cutting set

One cutter for ① external thread (ground to 60°, metric) one for ② internal thread, one ③ general cutting. Comes in wooden box with sliding lid. 8 x 8 x 80mm.

NO 24 540



Parting tool holder and tool

Used in the PD 250/E quick change system. Used to part stock and cut slots. The 12 x 3 x 85mm HSS tool contains cobalt. Spare tools available under NO 24 554.

NO 24 217



Spare tool for parting tool holder (not depicted)

As described above.

NO 24 554

Cutter set with tungsten inserts

Three holders (90mm long):

- ① for roughing out;
- ② for longitudinal work;
- ③ for 90mm boring bar, holes from 12mm.

Standard tungsten inserts, 55°, plated (commercially available version). Three additional inserts securing screw and key TX 8 are included. 8 x 8mm.

NO 24 555



Tungsten disposable tips (not depicted)

For the holders as described above.

NO 24 557 Ten piece set

Three piece centre drill set

Made of HSS steel. DIN 333 (type A) 60°. Complete set centre drills with sizes of 2 - 2.5 and 3.15mm.

NO 24 630



HSS boring tool set, 6 pieces

One each cutter for 60 degree (metric) and 55 degree (Whitworth) inside threads, 2.5mm - 3mm and 4mm. Shaft of Ø 6mm. Length 95mm. The cutters are held by a tool holder (9 x 9mm) that mounts to the tool post of either PD 230/E, PD 250/E or PD 400. Comes in wooden box with sliding lid.

NO 24 520



Tool holder for rotary tools.

For use on lathe machines.

Made of steel with standard 20mm MICROMOT collar size. For precise clamping of rotary tool IBS/E or LBS/E in the tool post of the lathe. Shaft 8 x 10mm. Total length 65mm.

NO 24 098



Die holder for round dies

For threads M 3 - 4 - 5 - 6 - 8 and 10. With holder Ø 10mm for mounting in the tailstock drill chuck of the lathe. The holder is held by hand while cutting the threads. Neatly packed in wooden box with sliding lid.

NO 24 082

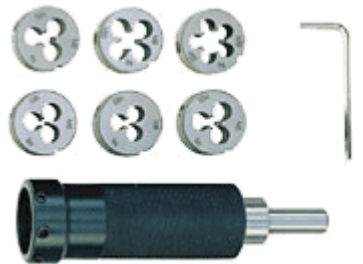

Mill and drill head PF 230

Converts your lathe PD 250/E or PD 400 into a complete machining centre.

Includes column (35 x 400mm), mounting bracket and fastening screws (the PD 250/E and PD 400 already come with a plane-milled surface). The lathe's top slide is replaced with the table (supplied) of 110 x 70mm, with 3 T-slots 12 x 6 x 5mm. The lathe now functions as a compound table, with X-Y travel being longitudinally and cross-wise respectively. The mill/drill head is identical to the MICRO miller FF 230. Three collets of sizes 6 - 8 and 10mm are included.

NO 24 104

Note:

Lathe not included.



Accessories for the PF 230

Fine feed for milling machine PF 230

Easily installed in a few seconds. The feed may be used via either the height feed (vertical) or the fine feed in the tilted position. The graduated scale may be zero reset. One revolution is equivalent to 1.5mm spindle travel (1 division = 0.05mm).

NO 24 140



Gear tooth chuck (10mm) with adapter

Industrial quality, however not as accurate as the collets. With 10mm adapter which fits into the 10mm collet. Includes the chuck key.

NO 24 110



Five piece collet set (not depicted)

Includes 1 each of 2.4 - 3 - 3.2 - 4 and 5mm, for milling cutters. Supplied in a wooden box with sliding lid.

NO 24 144

Step clamp set of steel.

2 step blocks and clamps each.

With matching slot nuts and fastening screws for T-slots as per MICROMOT standard (12 x 6 x 5mm). In wooden box with sliding lid.

NO 24 256 For work pieces up to 20mm thickness

NO 24 257 For work pieces up to 35mm thickness

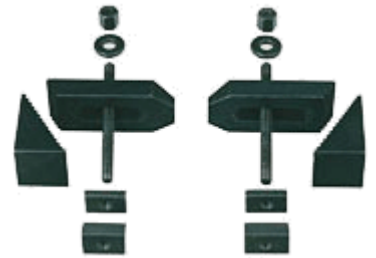

Compound table KT 230

As described at MICRO miller FF 230 and FF 250/BL, but excluding headstock and column. With 34mm bore to mount the PF 230 and PF 250/BL mill/drill head (the end fitting of the mill head's 35mm column is machined to 34mm).

NO 24 106

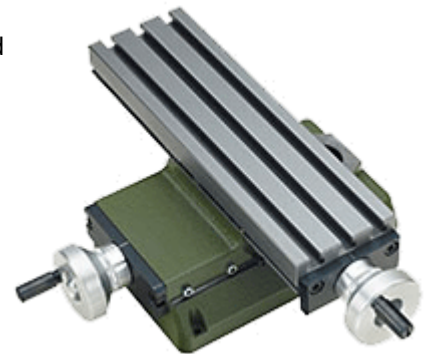

Milling cutter set (2 - 5mm)

All cutters with 6mm shaft. Cutters of Ø 2 - 3 - 4 and 5mm. Double fluted according to DIN 327. Made of HSS-Co5. Supplied in wooden box with sliding lid.

NO 24 610



Milling cutter set (6 - 10mm)

4 cutters Ø 6 - 7 - 8 and 10mm. Four flute design according to DIN 844. Shafts 6 and 10mm respectively. Made of HSS-Co5. Supplied in wooden box with sliding lid.

NO 24 620



Precision vice PM 60

Jaw width 60mm. Clamping capacity 42mm. Total length 100mm.

NO 24 255



Precision V-blocks

Used to clamp various work pieces.

Made from hardened steel, precision ground in pairs. Four different depths of prism incisions V, all at 90°. Size 50 x 30 x 30mm. The solid clamp and knurled knob ensure superb securing of the workpiece. Supplied in a wooden box with sliding lid.

NO 24 262 2 pieces

